

Oscilloscope adaptateur 4 traces

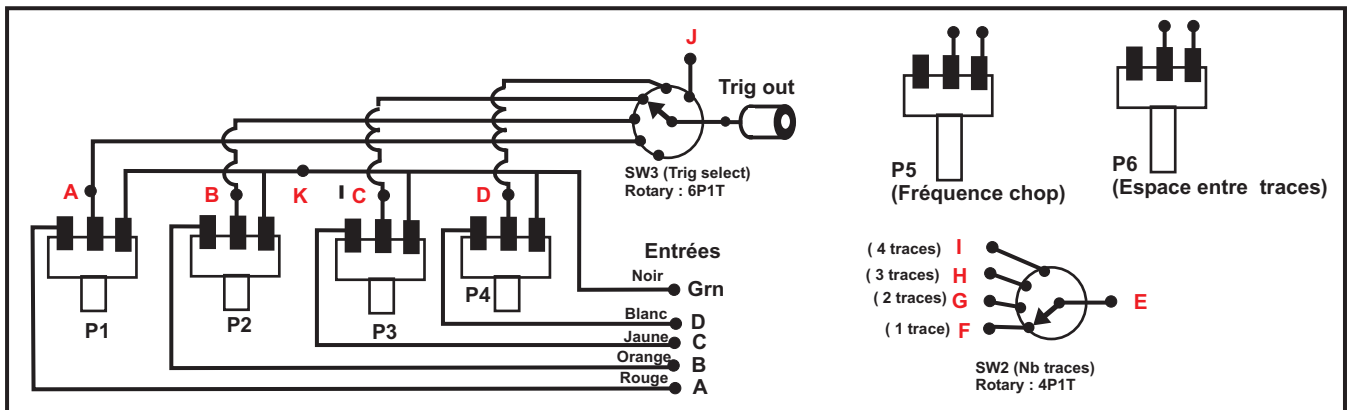

Adaptation du du schéma original de L. Gendron (Handy Dandy Little Circuits) sur Internet

(Suite page suivante)
Circuit imprimé

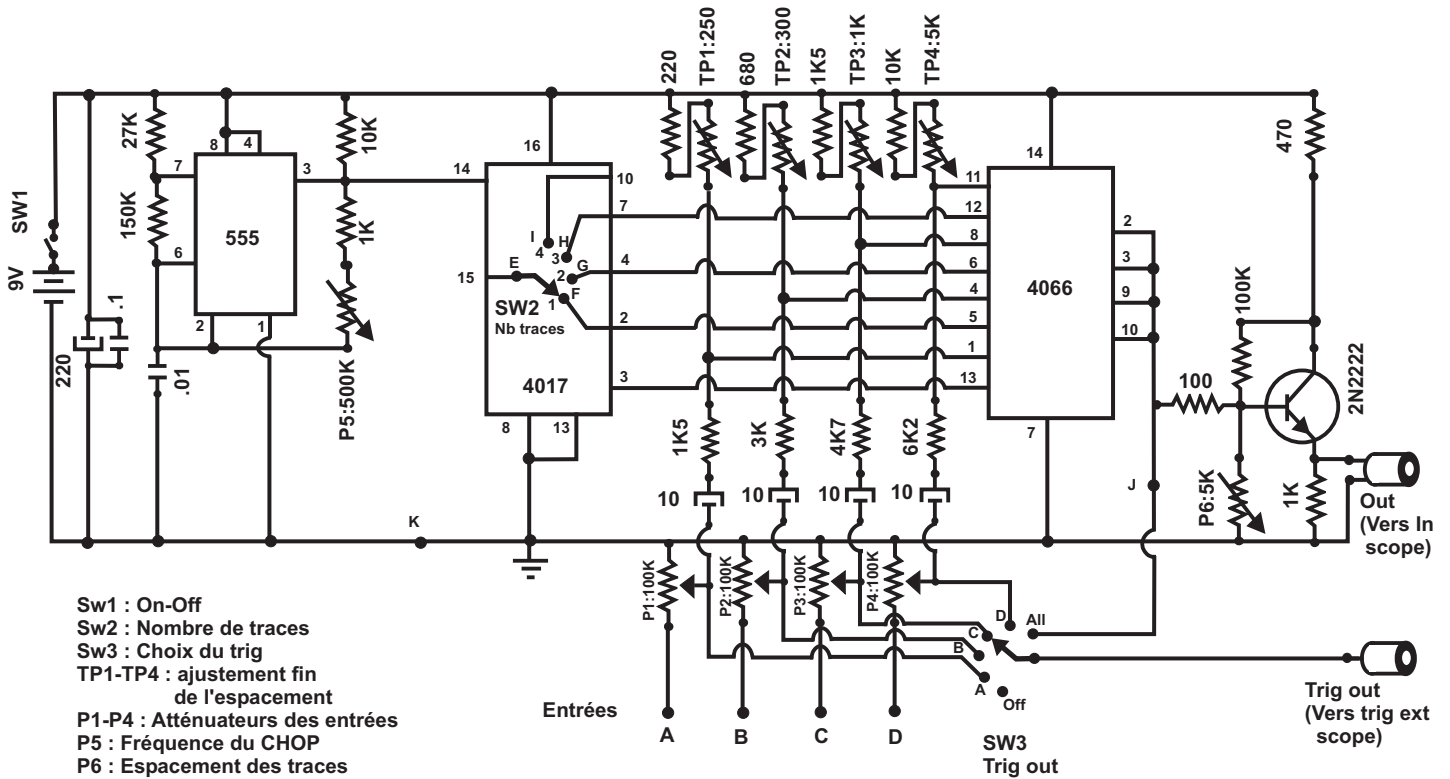